

Item # _____



RCO Convection Oven

STANDARD FEATURES:

- ◆ Bakery Pan Depth, accomodates full size Sheet Pans front to back and side to side.
- ◆ 80,000 BTU oven burner for rapid heat up and recovery.
- ◆ Electric thermostat adjustable from 150° to 500° F.
- ◆ Two speed motor to select best air circulation for desired results.
- ◆ Air deflectors strategically placed around the blower for efficient air circulation.
- ◆ Cool Touch Controls set back for protection.
- ◆ Electronic ignition with 100% safety.
- ◆ Glass Window in the right hand door next to controls with two interior lights let the chef easily observe food product.
- ◆ Oven interior is porcelain coated for protection from spills.
- ◆ Both doors feature stainless steel interior and exterior for durability and ease in cleaning.
- ◆ Oven doors swing open 135 degrees for easier access for loading and removing pans.
- ◆ 5 Chrome plated racks standard with 11 positions.
- ◆ All S/S Front, sides and Top construction.
- ◆ Unique Stackable design requiring no additional flue extensions.



OPTIONS:

- ◆ Stainless Steel Bottom Shelf/Stand (RCO-1 only).
- ◆ Extra Rack Storage (RCO-1 only).
- ◆ Stacking Kit to stack (2) RCO-1 units (includes 6" legs).
- ◆ Heavy Duty Casters, Set of 4 (2 locking, 2 non locking).
- ◆ Extra Oven Racks.
- ◆ Glass View Door for Left Side (right side is standard).
- ◆ Direct Connect Vent Kit

Royal Bakery Depth Convection ovens are engineered for outstanding performance, long life and maximum value. They are constructed with a rugged interior frame, stainless steel sides, top and front. The interior surfaces are porcelain coated for durability and easy cleaning. The ample oven chamber accomodates full size sheet pans, front to back or side to side. Unlike many other brands we include as standard a glass viewing door on the right, adjacent to the controls for easier regulation while monitoring the food product inside. In addition, our unique design permits stacking two single ovens in the field with simple tools and requires no additional flue exhaust kit.



RCO Convection Oven Specifications

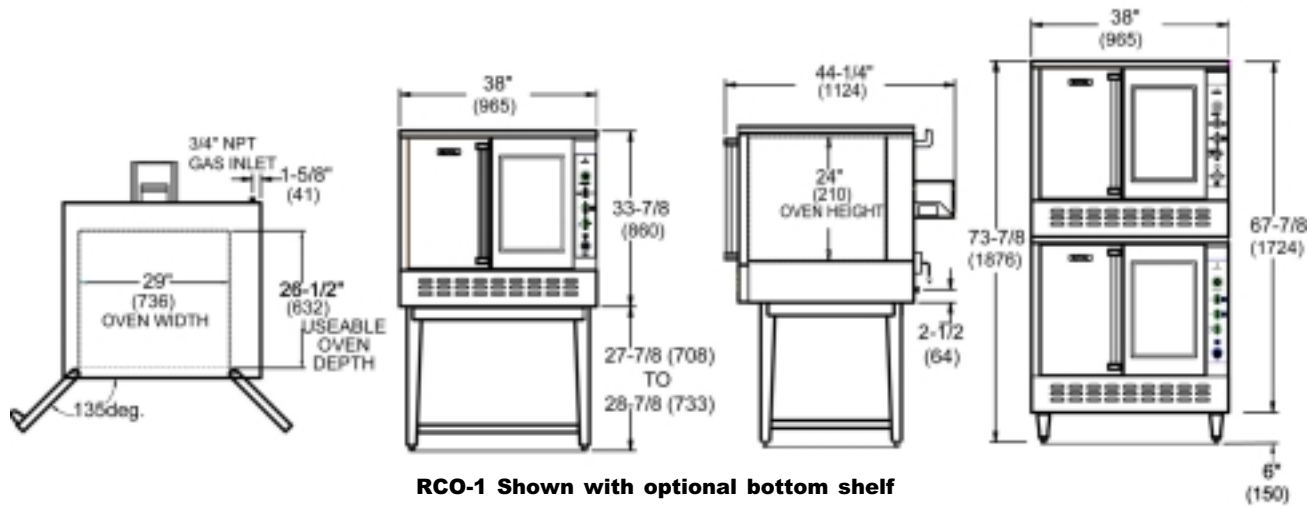

MODEL NO.	WIDTH	DEPTH	NUMBER * OF BURNERS	TOTAL BTU's.	SHIP WEIGHT
RCO-1	38"	44-1/4"	2	80,000	600 Lbs.
RCO-2	38"	44-1/4"	4	160,000	1185 Lbs.
* Note: 40,000 BTU/Hr. each burner.					

Electrical requirements: 120V 50-60hz AC, Single phase.

8 amps per oven (single).

Two speed motor (1725 / 1140 RPM) 1/3 HP, 1.35SF.

Provided with 6' power cord fitted with a standard three prong grounded plug.

Gas Connection: 3/4" NPT on the right hand rear of the appliance
The pressure regulator (supplied) is to be connected here by the installer.

Gas pressure: 5" W.C. - Natural Gas
10" W.C. - Propane

Combustible Clearances:

6 inches sides
6 inches rear

Non-combustible Clearances:

0 inches sides
0 inches rear

**Specify type of gas and altitude,
if over 2,000 feet, when ordering.**

Due to continuing product development to ensure best possible performance, these specifications are subject to change without prior notification

1768 WEST FIRST STREET AZUSA, CA. 91702-3259 626.812.4434 FAX 626.812.4437 (11/04)